

TURBO-AIRE series



3 Speed Centrifugal In-Line Fan



GTG Industries Sdn Bhd certifies that the model: GCIL shown herein is licensed to bear the AMCA Seal. The ratings shown are based on tests and procedures performed in accordance with AMCA Publication 211 and AMCA Publication 311 and comply with the requirements of the AMCA Certified Ratings Program.



3 Speed Centrifugal In-Line Fan

TURBO-AIRE series

- ◆ Backward curve centrifugal impeller.
- ◆ Uniquely designed 3 speed external rotor motor.
- ◆ Speed Controllable.
- ◆ Compact in size.
- ◆ Lighter in weight.
- ◆ Higher in efficiency.
- ◆ Lower in sound.

Introduction

TURBO-AIRE SERIES is designed to cater for the high air flow and high static pressure requirements.

It is light weight and has excellent performance to sound level ratio. The uniquely designed 3 speed external rotor motor provides additional choices for different applications.



Casing

Manufactured from rust-resistance pre-galvanised steel.

Aerodynamically designed inlet guide vane ensures high efficiency performance at low sound level.

Impeller

Backward curve centrifugal.

Motor

Uniquely designed 3 speed external rotor motor.

Moisture resistant, suitable for humid and damp environments.

Permanently lubricated ball bearing ensuring reliable and maintenance-free operation.

Class F insulation.

Speed controllable.

Suitable for operation in ambient temperatures ranging from -14°C to +40°C.

Built-in thermal protection device.

Accessories (Optional)

Outlet Duct Cap



GAC Series

Outlet Duct Cap (with Grille)



GACG Series

Intake Louver Kit



GAT Series

Performance Curves

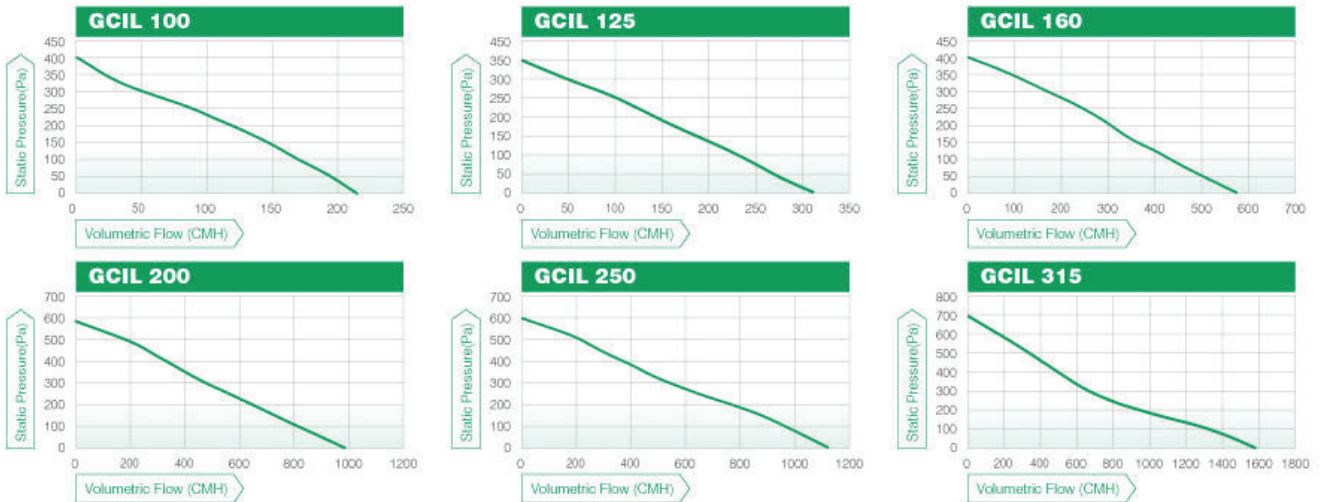

Specification

Model	GCIL 100	GCIL 125	GCIL 160	GCIL 200	GCIL 250	GCIL 315
Speed	High	High	High	High	High	High
Volt / Phase / Hz	240 / 1 / 50	240 / 1 / 50	240 / 1 / 50	240 / 1 / 50	240 / 1 / 50	240 / 1 / 50
Max Power Input (W)	68	72	130	187	214	288
Air Flow (CMH)	214	312	577	975	1137	1573
Amps (A)	0.28	0.3	0.54	0.74	0.85	1.14
RPM	2729	2684	2573	2376	2376	2317
Sound Power dB(A)	78.0	77.5	80.5	79.5	78.5	80.0
Sound Pressure dB(A) at 3m	57.0	56.5	59.5	58.5	57.5	59.0

*Speed(RPM) shown is nominal. Performance is based on actual speed of test.

*LpA-dBA levels are not licensed by AMCA International.

*Performance certified is for installation type D- Ducted inlet, Ducted outlet. Performance ratings do not include the effects of appurtenances (accessories).

*The A-weighted sound ratings shown have been calculated per AMCA International Standard 301. Values shown are for inlet LwA sound power levels for installation type D ducted inlet, ducted outlet. Ratings include the effects of duct end correction.

Dimension (mm)

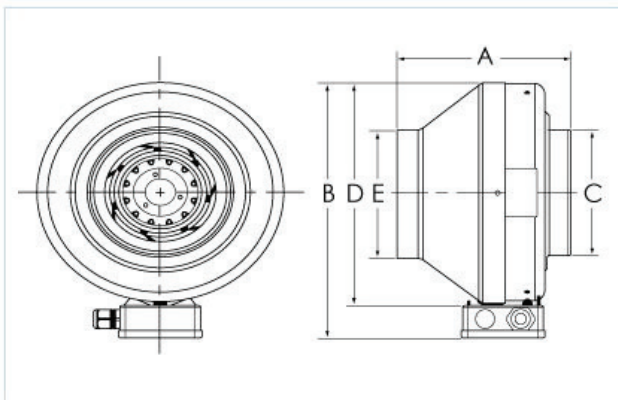

MODEL	A	B	C	D	E	WEIGHT (Kg)
GCIL 100	203.5	279.0	100.0	236.5	100.0	3.8
GCIL 125	193.0	279.0	125.0	236.5	125.0	3.8
GCIL 160	195.0	323.0	160.0	278.0	160.0	4.5
GCIL 200	234.5	378.0	200.0	333.0	200.0	6.6
GCIL 250	211.0	377.5	250.0	333.0	250.0	6.8
GCIL 315	265.0	446.0	385.0	401.5	315.0	8.4

Specifications subject to changes without prior notice.

Accessories (Optional)

GAC Series	GA4C	GA6C
A	155	202
B	15	18
C	100	150
D	98	118

GACG Series	GA4CG	GA6CG
A	155	202
B	25.5	25.5
C	100	150
D	66	66

GAT Series	GA6T	GA8T
A	290	324
B	264	296
C	248	278
D	92	88
E	18	18
F	145	190

3 Speed Centrifugal In-Line Fan



Turbo-Aire Series

- 1 Backward Curve Centrifugal Impeller.
- 2 Uniquely Designed 3 Speed External Rotor Motor.
- 3 Speed Controllable.
- 4 Compact In Size.
- 5 Lighter In Weight.
- 6 Higher In Efficiency.
- 7 Lower In Sound.



SCAN & VISIT OUR WEBSITE

GTG Industries Sdn Bhd

(Formerly known as Grand Everise Sdn Bhd)
(912584-W)

Lot 9, Jalan 13/6, 46200 Petaling Jaya, Selangor, Malaysia.

TEL +603-7957 0212 / +603-7957 0223 FAX +603-7957 0398

EMAIL inquiry@gtg.com.my WEBSITE www.gtg.com.my